

# Series **1800**

## **product guide**

### features

- **142' Five-Section Boom**
- **40 Ton Rating**
- **Self-lubricating "Easy Glide" Wear Pads**
- **Tailswing Counterweight**



### contents

Features	<b>2</b>
Mounting Configurations	<b>3</b>
Specifications	<b>4</b>
Capacities: With 26' Jib	<b>5</b>
Mid-Span Capacities w/26' Jib	<b>6</b>
Accessories	<b>7</b>

# features

## Why Buy a National Series 1800?

2



\*Product may be shown with optional equipment.

- **40 ton Rating** – The 1800 provides a 40-ton capacity, an 11% increase in capacity over the Series 1500.
- **142 ft. Five-section Boom** – The longest in its size range. The long boom allows the operator to perform more lifts without the use of a jib, reducing setup time and improving efficiency. Also available are optional boom lengths of 79', 103' and 127'.
- **Overload Protection** – All National cranes are equipped with overload protection:
  - Load Moment Indicator (LMI) standard on all Series 1800 machines.
  - LMI display and CPU are weatherproof.
  - LCD display is visible in full or low light.
  - All crane load lifting values are displayed simultaneously.
- **Stronger Torsion Box** – The stronger standard torsion box improves rigidity, reduces truck frame flex and reduces the need for counterweight.
- **Speedy-reeve Boom Tip and Sheave Blocks** – These standard features simplify rigging changes by decreasing the time needed to change line reeving.
- **Pre-painted Components** – Painting crane components before assembly reduces the possibility of rust, improves serviceability and enhances the appearance of the machine.
- **Self-lubricating “Easy glide” Boom Wear Pads** – The standard self-lubricating boom pads reduce the conditions that cause boom chatter and vibration. The net result is smoother crane operation.
- **Deluxe Operator’s Cab** – Rigid galvanized steel structure, well insulated, with ample safety glass for operator visibility and comfort. Multi-position seat with arm rest controls, ventilation fans, diesel heater, wipers. Optional air-conditioning is available.
- **Outrigger** – Outrigger span of 24'8" when full extended; 17'6" at mid-span.
  - Ground-level outrigger controls on both sides.
  - In-cab outrigger controls for all functions.
  - Front bumper stabilizer for stable base over front.
- **Improved Serviceability** –
  - Boom sections are supported by one hydraulic extend cylinder, minimizing maintenance.
  - Bearings on the boom extend and retract cables can be greased through access holes in the boom side plates.
  - Pre-paint reduces rust.
- **New State-of-the-art Control Valve** – Provides smoother operation. The new load-sensing, pressure-compensated design greatly enhances function meterability, eliminates parts, reduces repair costs and improves the machine’s serviceability.
- **National Crane Is the Market Leader** – National is number one in the production of commercial truck-mounted boom trucks. National has the resources, programs and people to provide our customers with reliable products.
- **National has the boom truck industry’s leading test program.** Every structural part of the crane is cycle tested, some up to 60,000 cycles at full capacity. In addition to cycle testing, each model is subjected to state-of-the-art strain gauge testing that measures metal deformation as small as one-millionth of an inch. The net result is that weak areas are caught in test, not on job sites where costly downtime occurs.
- Parts are available for all National Crane machines, even if they are 35 years old.
- National has a formalized quality program and is ISO 9001 approved.
- You Expect National Crane to be a Quality Product That Will Provide Years of Service, and So Do We

- 40-ton (36.29-t) maximum capacity
- 190 ft. (57.91 m) maximum vertical reach\*
- 149 ft. (45.42 m) maximum vertical hydraulic reach\*
- Load Moment Indicator system (LMI)
- Proportional boom extension
- High performance planetary winch
- Vickers PVH 131 pressure compensated, load sensing, axial piston, variable volume pump mounts direct to PTO.

- \* Maximum vertical reach is ground-level to boom tip height at maximum extension and angle with outriggers/stabilizers fully extended.

1800

# mounting configurations

The configurations are based on the Series 1800 with an 85% stability factor. The complete unit must be installed in accordance with factory requirements and a test performed to determine actual stability and counterweight requirements since individual truck chassis vary.

## 1800 w/Tag Axle 60,000 GVWR (79/103/127' Boom)

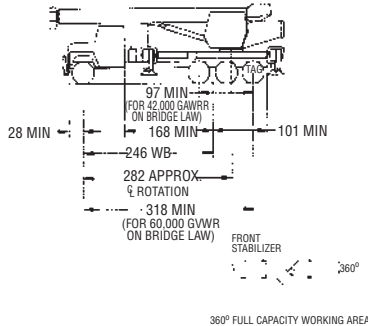

## Configuration 1 – 79' - 103' - 127' Boom with Tag Axle

Working area	360'
Gross Axle Weight Rating Front	20,000 lb (9072 kg)
Gross Axle Weight Rating Rear	40,000 lb (18 144 kg)
Gross Vehicle Weight Rating	60,000 lb (27 216 kg)
Wheelbase	246 in (625 cm)
Cab to Axle/trunnion (CA/CT)	168 in (427 cm)
Frame Section Modulus (SM), front axle to end of AF: 110,000 PSI (785 MPa)	30.0 in <sup>3</sup> (426 cm <sup>3</sup> )
Stability Weight, Front	9,450 lb (4286 kg) minimum*
Stability Weight, Rear	10,800 lb (4899 kg) minimum*
Estimated Average Final Weight	56,945 lb (25 830 kg)**

This configuration shows the 360° working area that is achieved with the front stabilizer (standard on the Series 1800). The front stabilizer is essential when extending the boom and lifting loads over the front of the truck.

\*Estimated axle scale weights prior to installation of crane, stabilizers and subbase for 85% stability.

\*\*Estimated final weight (wet) with 127 ft (38.72 m) boom, 400 lb (182 kg) 3 part block, steel decks, 2,300 lb (1,045 kg) swinging counterweight, 100-gal (379-L) fuel tank and two workers in cab.

## 1800 w/Pusher Axle 58,000 GVWR (79/103/127' Boom)

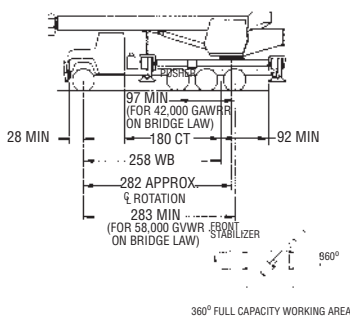

## Configuration 2 – 79' - 103' - 127' Boom with Pusher Axle

Working area	360'
Gross Axle Weight Rating Front	20,000 lb (9072 kg)
Gross Axle Weight Rating Rear	40,000 lb (18 144 kg)
Gross Vehicle Weight Rating	60,000 lb (27 216 kg)
Wheelbase	258 in (655 cm)
Cab to Axle/trunnion (CA/CT)	180 in (457 cm)
Frame Section Modulus (SM), front axle to end of AF: 110,000 PSI (785 MPa)	30.0 in <sup>3</sup> (426 cm <sup>3</sup> )
Stability Weight, Front	9,975 lb (4525 kg) minimum*
Stability Weight, Rear	10,275 lb (4661 kg) minimum*
Estimated Average Final Weight	56,945 lb (25 830 kg)**

This configuration shows the 360° working area that is achieved with the front stabilizer (standard on the Series 1800). The front stabilizer is essential when extending the boom and lifting loads over the front of the truck.

\*Estimated axle scale weights prior to installation of crane, stabilizers and subbase for 85% stability.

\*\*Estimated final weight (wet) with 127 ft (38.72 m) boom, 400 lb (182 kg) 3 part block, steel decks, 2,300 lb (1,045 kg) swinging counterweight, 100-gal (379-L) fuel tank and two workers in cab.

## 1800 w/Tag Axle 60,000 GVWR (142' Boom)

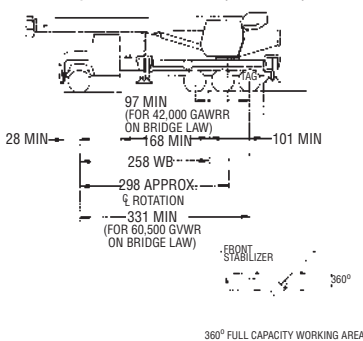

## Configuration 142' Boom with Tag Axle

Working area	360'
Gross Axle Weight Rating Front	20,000 lb (9072 kg)
Gross Axle Weight Rating Rear	40,000 lb (18 144 kg)
Gross Vehicle Weight Rating	60,000 lb (27 216 kg)
Wheelbase	258 in (655 cm)
Cab to Axle/trunnion (CA/CT)	168 in (427 cm)
Frame Section Modulus (SM), front axle to end of AF: 110,000 PSI (785 MPa)	30.0 in <sup>3</sup> (426 cm <sup>3</sup> )
Stability Weight, Front	9,275 lb (4207 kg) minimum*
Stability Weight, Rear	10,575 lb (4797 kg) minimum*
Estimated Average Final Weight	58,000 lb (26 308 kg)**

This configuration shows the 360° working area that is achieved with the front stabilizer (standard on the Series 1800). The front stabilizer is essential when extending the boom and lifting loads over the front of the truck.

\*Estimated axle scale weights prior to installation of crane, stabilizers and subbase for 85% stability.

\*\*Estimated final weight (wet) with 142 ft (43.29 m) boom, 400 lb (182 kg) 3 part block, steel decks, 2,300 lb (1,045 kg) swinging counterweight, 100-gal (379-L) fuel tank and two workers in cab.

## MINIMUM TRUCK REQUIREMENTS

Many factors must be considered in the selection of proper truck for a 1800 series crane. Items which must be considered are:

- 1. Axle Rating.** Axle ratings are determined by the axles, tires, rims, springs, brakes, steering and frame strength of the truck. If any one of these components is below the required rating, the gross axle rating is reduced to its weakest component value.
- 2. Wheelbase (WB), Cab-to-Trunnion (CT) and Bare Chassis Weight.** The wheelbase, CT and chassis weights shown are required so the basic 1800 can be legally driven in most states and meet stability requirements. The dimensions given assume the sub-base is installed properly behind the truck cab. If exhaust stacks, transmission protrusions, etc., do not allow a close installation to the cab, the WB and CT dimensions must be increased. Refer to the Mounting Configuration pages for additional information.
- 3. Truck Frame.** Try to select a truck frame that will minimize or eliminate frame reinforcement or extension of the after frame (AF). Many frames are

available that have the necessary after frame (AF) section modulus (S.M.) and resistance to bending moment (RBM) so that reinforcing is not required. The front hydraulic jack is used for a 360° working range around the truck. The frame under the cab through the front suspension must have the minimum S.M. and RBM because reinforcing through the front suspension is often difficult because of engine, radiator mounts and steering mechanics. See "Truck Requirements" and "Frame Strength" pages for the necessary section modulus and resistance to bending moment values.

- 4. Additional Equipment.** In addition to the axle ratings, wheelbase, cab-to-axle requirements and frame, it is recommended that the truck is equipped with electronic engine control, increased cooling and a transmission with a PTO opening available with an extra heavy duty PTO. See "PTO Selection" pages. A conventional cab truck should be used for standard crane mounts.
- 5. Neutral Start Switch.** The chassis must be equipped with a switch that prevents operation of the engine starter when the transmission is in gear.

### Notes:

- Gross Vehicle Weight Rating (GVWR) is dependent on all components of the vehicle (axles, tires, springs, frame, etc.) meeting manufacturers' recommendations; always specify GVWR when purchasing trucks
- Diesel engines require a variable speed governor and energize-to-run fuel solenoid for smooth crane operation; electronic fuel injection requires EET engine remote throttle

- All mounting data is based on a National Series 1800 with an 85 percent stability factor (75% stability factor for New York City).
- The complete unit must be installed in accordance with factory requirements, and a test performed to determine actual stability and counterweight requirements per SAE J765; contact the factory for details

3

1800

# specifications

4

## Boom and Jib Combinations Data

Available in four basic models: 1879 three-section, 18103 four-section, 18127 five-section and 18142 five-section.

**Model 1879** – Equipped with a 31-79 ft (9.45-24.08 m) three-section boom. There are no jib options for this boom model. Maximum tip height is 87 ft (26.52 m).

31-79 ft (9.45-24.08 m) three-section hydraulic boom



**Model 18103** – Equipped with a 31-103 ft (9.45-31.40 m) four-section boom. This model can be equipped with a 31 ft (9.45 m) jib, offering a vertical reach of 142 ft (43.29 m) and a 31-55 ft (9.45-16.76 m) side-stowing foldaway jib, providing a vertical reach of 166 ft (50.60 m).

31-103 ft (9.45-31.40 m) four-section hydraulic boom



31-103 ft (9.45-31.40 m) four-section hydraulic boom      **18FJ31OS** 31 ft (9.45 m) single-section offsettable manual jib



31-103 ft (9.45-31.40 m) four-section hydraulic boom      **18FJ55** 31-55 (9.45-16.76 m) two-section manual jib



**Model 18127** – Equipped with a 31-127 ft (9.45-38.72 m) five-section boom. This model can be equipped with a 31 ft (9.45 m) jib, offering a vertical reach of 166 ft (50.60 m) or a 31-55 ft (9.45-16.76 m) jib providing a vertical reach of 190 ft (57.91 m).

31-127 ft (9.45-38.72 m) five-section hydraulic boom



31-127 ft (9.45-38.72 m) five-section hydraulic boom      **18FJ31** 31 ft (9.45 m) single-section manual jib



31-127 ft (9.45-38.72 m) five-section hydraulic boom      **18FJ55** 31-55 (9.45-16.76 m) two-section manual jib



**Model 18142** – Equipped with a 34-142 ft (10.36-43.29 m) five-section boom. This model can be equipped with a 26 ft (7.92 m) jib, offering a vertical reach of 176 ft (53.64 m).

34-142 ft (10.36-43.29 m) five-section hydraulic boom



34-142 ft (10.36-43.29 m) five-section hydraulic boom      **18FJ26** 26 ft (7.92 m) single-section manual jib



**Note:** maximum tip height is measured with outriggers/stabilizers fully extended.

## 1800 Winch Data

- All winch pulls and speeds are shown on the fifth layer.
- Winch line pulls would increase on the first, second, third and fourth layers.
- Winch line speed would decrease on the first, second, third and fourth layers.
- Winch line pulls may be limited by the winch capacity or the ANSI 5 to 1 cable safety factor.

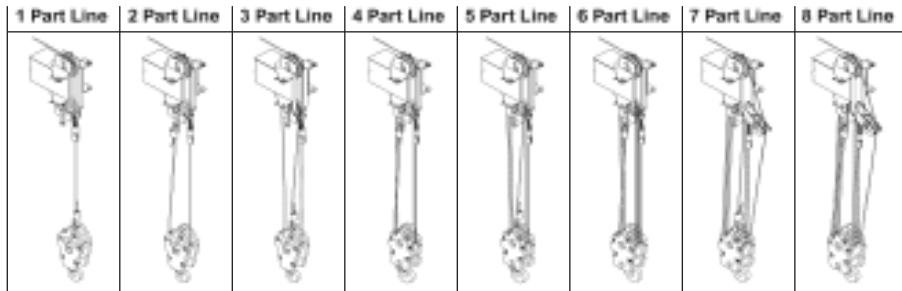

Standard Planetary Winch	Cable Supplied	Average Breaking Strength	Lift and Speed	Lift and Speed	Lift and Speed	Lift and Speed	Lift and Speed	Lift and Speed	Lift and Speed	Lift and Speed
Low Speed	5/8" diameter rotation resistant IWRC	56,400 lbs. (25583 kg)	10,000 lbs. (4536 kg) 205 fpm (62 m/min)	20,000 lbs. (9072 kg) 103 fpm (31 m/min)	30,000 lbs. (13608 kg) 68 fpm (21 m/min)	40,000 lbs. (18144 kg) 51 fpm (16 m/min)	50,000 lbs. (22680 kg) 41 fpm (13 m/min)	60,000 lbs. (27216 kg) 34 fpm (10 m/min)	70,000 lbs. (31751 kg) 29 fpm (9 m/min)	80,000 lbs. (36287 kg) 26 fpm (8 m/min)
High Speed	5/8" diameter rotation resistant IWRC	56,400 lbs. (25583 kg)	5,000 lbs. (2268 kg) 410 fpm (125 m/min)	10,000 lbs. (4536 kg) 205 fpm (62 m/min)	15,000 lbs. (6804 kg) 137 fpm (42 m/min)	20,000 lbs. (9072 kg) 103 fpm (31 m/min)	25,000 lbs. (11340 kg) 82 fpm (25 m/min)	30,000 lbs. (13608 kg) 68 fpm (21 m/min)	35,000 lbs. (15876 kg) 59 fpm (18 m/min)	40,000 lbs. (18144 kg) 51 fpm (16 m/min)

**Winch**  
Standard planetary  
& Auxiliary planetary

**Full Drum Pull**  
5,000 pounds (2268 Kg high speed)  
10,000 pounds (4536 Kg low speed)

**Allowable Cable Pull**  
11,280 pounds (5117 Kg)  
11,280 pounds (5117 Kg)

5 TON	Aux Boom Head	100 LB.	(45 kg)
15 TON	Downhaul Weight	180 LB.	(82 kg)
25 TON	1 Sheave Block	375 LB.	(170 kg)
35 TON	2 Sheave Block	640 LB.	(290 kg)
40 TON	3 Sheave Block	870 LB.	(395 kg)
	4 Sheave Block	970 LB.	(440 kg)

1800

## Load Rating Chart: Series 1800 with 26 ft. Jib

Other Series 1800 Load Rating Charts are available. National will send you a chart on request – or you may secure needed load rating information through your nearest National dealer.

5

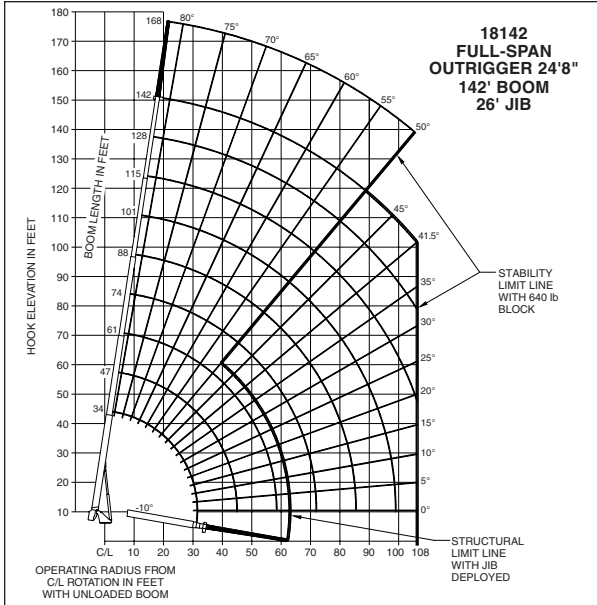

### CAUTION:

- Do not operate crane booms, jib extensions, any accessories or loads within 10 ft (3m) of live power lines or other conductors of electricity.
- Jib and boom capacities shown are maximum for each section.
- Do not exceed capacities at reduced radii.
- Load ratings shown on the load rating charts are maximum allowable loads with the outriggers properly extended on a firm, level surface and the crane leveled and mounted on a factory recommended truck.
- Always level the crane with the level indicator located on the crane.
- The operator must reduce load to allow for factors such as wind, ground conditions, operating speeds and their effects on freely suspended loads.
- Overloading this crane may cause structural collapse or instability.
- Weights on any accessories attached to the boom or loadline must be deducted from the load chart capacities.
- Do not exceed jib capabilities at any reduced boom lengths.
- Do not deadhead lineblock against boom tip when extending boom or winching up.
- Keep at least three wraps of loadline on drum at all times.
- Use only specified cable with this machine.

## SERIES 18142 WITH 26' JIB

### NOTE:

- Operate with jib by radius when main boom is fully extended. If necessary increase boom angle to maintain loaded radius.
- Operate with jib by boom angle when main boom is not fully extended. Do not exceed rated jib capacities at any reduced boom lengths.
- Capacities do not exceed 85% stability.
- Shaded areas are structurally limited capacities.

## Load Rating: 34-142 ft Boom Rated Loads without jib

34 FT BOOM			47 FT BOOM			61 FT BOOM			74 FT BOOM			NOTE: 1. All capacities are in pounds, angles in degrees, radius in feet. 2. Loaded boom angles are given as reference only. 3. Shaded areas are structurally limited capacities.		
Radius	Angle	Capacity	Radius	Angle	Capacity	Radius	Angle	Capacity	Radius	Angle	Capacity			
7	76.3	80,000												
8	74.3	74,000												
10	70.5	63,000	10	76.6	40,000									
12	66.7	55,000	12	74.2	40,000	12	78.7	40,000						
15	60.6	43,000	15	70.5	40,000	15	75.8	36,000	15	79.2	32,000			
20	49.6	29,700	20	63.6	30,600	20	70.8	30,000	20	75.2	26,600			
25	36.4	22,000	25	56.2	22,800	25	65.4	23,000	25	71	21,500			
30	16.2	17,000	30	48.1	17,700	30	59.8	17,900	30	66.6	17,400			
	0	15,800	35	38.9	14,100	35	53.8	14,300	35	62.1	14,400			
			40	27.1	11,400	40	47.4	11,600	40	57.4	11,800			
				0	9,400	45	40.9	9,700	45	52.9	9,900			
						50	32.6	8,900	50	47.6	8,200			
						55	21.5	6,800	55	41.7	6,900			
							0	5,900	60	35.1	5,700			
									65	27.1	4,850			
									70	15.4	4,000			
										0	3,800			
88 FT BOOM			101 FT BOOM			115 FT BOOM			128 FT BOOM			142 FT BOOM		
Radius	Angle	Capacity	Radius	Angle	Capacity	Radius	Angle	Capacity	Radius	Angle	Capacity	Radius	Angle	Capacity
20	78.2	23,000	20	79.9	17,000									
25	74.9	20,000	25	77.2	15,800	25	79.1	13,000						
30	71.3	17,000	30	74.4	14,200	30	76.7	11,900	30	78.5	9,500	30	79.7	8,000
35	67.7	14,600	35	71.5	12,700	35	74.2	10,900	35	76.5	9,000	35	77.8	7,500
40	63.8	11,900	40	68.3	10,800	40	71.9	9,800	40	74.4	8,500	40	75.9	7,000
45	60.3	10,000	45	65.4	9,500	45	69.3	9,000	45	72.1	7,800	45	73.9	6,400
50	56.2	8,300	50	62.1	8,200	50	66.5	8,000	50	69.6	7,000	50	71.8	5,800
55	51.9	7,000	55	58.6	7,000	55	63.6	7,100	55	67.1	6,200	55	69.5	5,200
60	47.3	5,800	60	54.9	5,800	60	60.5	5,900	60	64.4	5,300	60	67.3	4,700
65	42.3	4,900	65	51.1	4,950	65	57.3	5,000	65	61.7	4,600	65	65	4,200
70	36.8	4,100	70	47.1	4,150	70	54	4,200	70	59	4,000	70	62.7	3,750
75	30.5	3,400	75	42.7	3,450	75	50.5	3,500	75	56.2	3,400	75	60.2	3,300
80	22.5	2,800	80	38.1	2,850	80	46.9	2,900	80	53.2	2,900	80	57.8	2,950
85	8.6	2,300	85	32.8	2,300	85	43.1	2,350	85	50	2,350	85	55.1	2,400
	0	2,200	90	26.5	1,850	90	39	1,900	90	46.8	1,900	90	52.3	1,950
			95	18.3	1,450	95	34.4	1,500	95	43.3	1,500	95	49.4	1,500
				0	1,100	100	29.3	1,100	100	39.6	1,100	100	46.5	1,150
						105	23	750	105	35.7	800	105	43.4	800
						108	18.3	650	108	33.1	650	108	41.5	650
RATED LOAD REDUCTIONS WITH JIB														
BOOM LENGTH	26 FT JIB STOWED			26 FT JIB ERECTED			26 FT JIB RATED LOADS							
	Radius Fully Extended	Loaded Boom Angle	Rated Loads All Boom Lengths	Radius Fully Extended	Loaded Boom Angle	Rated Loads All Boom Lengths	Radius Fully Extended	Loaded Boom Angle	Rated Loads All Boom Lengths					
34'		Reduce load 525 lb			Reduce load 1,050 lb	33	80	4,000						
47'		Reduce load 400 lb			Reduce load 1,000 lb	50	75	3,800						
61'		Reduce load 300 lb			Reduce load 950 lb	65	70	3,200						
74'		Reduce load 250 lb			Reduce load 925 lb	78	65	2,450						
88'		Reduce load 200 lb			Reduce load 900 lb	90	60	1,800						
101'		Reduce load 200 lb			Reduce load 900 lb	101	55	1,250						
115'		Reduce load 150 lb			Reduce load 875 lb	112	50	650						
128'		Reduce load 150 lb			Reduce load 875 lb									
142'		Reduce load 125 lb			Reduce load 850 lb									

THIS CHART IS ONLY A GUIDE AND SHOULD NOT BE USED TO OPERATE THE CRANE. The individual crane's load chart, operating instructions and other instructional plates must be read and understood prior to operating the crane.

# capacities

## Load Rating Chart: Series 1800 with 26 ft. Jib (mid-span outrigger)

Other Series 1800 Load Rating Charts are available. National will send you a chart on request – or you may secure needed load rating information through your nearest National dealer.

6

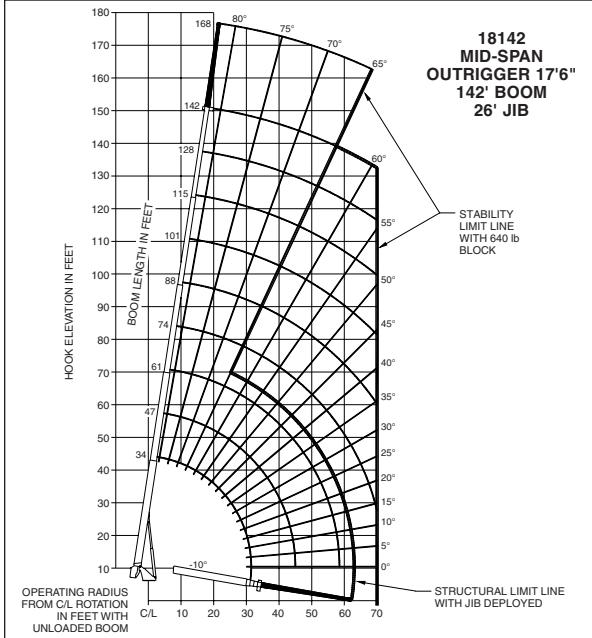

### CAUTION:

- Do not operate crane booms, jib extensions, any accessories or loads within 10 ft (3m) of live power lines or other conductors of electricity.
- Jib and boom capacities shown are maximum for each section.
- Do not exceed capacities at reduced radii.
- Load ratings shown on the load rating charts are maximum allowable loads with the outriggers properly extended on a firm, level surface and the crane leveled and mounted on a factory recommended truck.
- Always level the crane with the level indicator located on the crane.
- The operator must reduce load to allow for factors such as wind, ground conditions, operating speeds and their effects on freely suspended loads.
- Overloading this crane may cause structural collapse or instability.
- Weights on any accessories attached to the boom or loadline must be deducted from the load chart capacities.
- Do not exceed jib capabilities at any reduced boom lengths.
- Do not deadhead lineblock against boom tip when extending boom or winching up.
- Keep at least three wraps of loadline on drum at all times.
- Use only specified cable with this machine.

## 34 to 142 ft. Boom Rated Loads without 26 ft. Jib (mid-span outrigger)

**SERIES 18142  
WITH  
26' JIB  
(MID-SPAN  
OUTRIGGER)**

34 FT BOOM			47 FT BOOM			61 FT BOOM			74 FT BOOM			NOTE: 1. All capacities are in pounds, angles in degrees, radius in feet. 2. Loaded boom angles are given as reference only. 3. Shaded areas are structurally limited capacities.		
Radius	Angle	Capacity	Radius	Angle	Capacity	Radius	Angle	Capacity	Radius	Angle	Capacity			
7	76.3	80,000												
8	74.3	74,000												
10	70.5	63,000	10	76.6	40,000									
12	66.7	55,000	12	74.2	40,000	12	78.7	40,000	15	79.2	32,000			
15	60.6	43,000	15	70.5	40,000	15	75.8	36,000	20	75.2	26,600			
20	49.5	25,400	20	63.6	26,400	20	70.6	26,500	25	70.5	17,100			
25	36.3	15,900	25	55.9	16,700	25	65	17,000	30	65.9	11,900			
30	16.2	10,700	30	47.8	11,500	30	59.3	11,800	35	61.8	8,700			
0	9,500		35	39.4	8,300	35	53.9	8,600	40	57	6,400			
			40	27.9	6,000	40	47.4	6,300	45	52	4,800			
			0	4,300		45	40.3	4,600	50	46.7	3,600			
						50	31.9	3,400	55	40.9	2,600			
						55	20.7	2,400	60	34.3	1,800			
							0	1,750	65	26.2	1,100			
									70	14.5	650			
88 FT BOOM			101 FT BOOM			115 FT BOOM			128 FT BOOM			142 FT BOOM		
Radius	Angle	Capacity	Radius	Angle	Capacity	Radius	Angle	Capacity	Radius	Angle	Capacity	Radius	Angle	Capacity
20	78.2	23,000	20	79.9	17,000									
25	74.4	17,200	25	77.2	15,800	25	79.1	13,000						
30	70.5	12,000	30	74	12,100	30	76.7	11,900	30	78.5	9,500	30	79.7	8,000
35	67	8,800	35	70.9	8,900	35	74	9,000	35	76.5	9,000	35	77.8	7,500
40	63.1	6,500	40	67.6	6,600	40	71	6,700	40	73.6	6,700	40	75.7	6,700
45	59.2	4,950	45	64.3	5,100	45	68	5,200	45	71	5,200	45	73.3	5,200
50	55.1	3,700	50	60.8	3,800	50	65	3,900	50	68.3	3,900	50	70.8	3,900
55	50.8	2,700	55	57.3	2,800	55	62	2,900	55	65.6	2,900	55	68.4	2,900
60	46.2	1,900	60	53.7	2,000	60	59	2,100	60	62.9	2,100	60	66	2,100
65	41.3	1,200	65	49.9	1,300	65	55.8	1,400	65	60.2	1,400	65	63.5	1,400
70	35.8	700	70	45.9	750	70	52.6	800	70	57.4	800	70	61	800

RATED LOAD REDUCTIONS WITH JIB						26 FT JIB RATED LOADS		
BOOM LENGTH	26 FT JIB STOWED		26 FT JIB ERECTED		Radius Fully Extended	Loaded Boom Angle	Rated Loads All Boom Lengths	
	Reduce load	Capacity	Reduce load	Capacity				
34'	Reduce load 525 lb		Reduce load 1,050 lb		33	80	4,000	
47'	Reduce load 400 lb		Reduce load 1,000 lb		50	75	3,800	
61'	Reduce load 300 lb		Reduce load 950 lb		62	70	2,100	
74'	Reduce load 250 lb		Reduce load 925 lb		74	65	750	
88'	Reduce load 200 lb		Reduce load 900 lb					
101'	Reduce load 200 lb		Reduce load 900 lb					
115'	Reduce load 150 lb		Reduce load 875 lb					
126'	Reduce load 150 lb		Reduce load 875 lb					
142'	Reduce load 125 lb		Reduce load 850 lb					

THIS CHART IS ONLY A GUIDE AND SHOULD NOT BE USED TO OPERATE THE CRANE. The individual crane's load chart, operating instructions and other instructional plates must be read and understood prior to operating the crane.

1800

### Radio Remote Controls – (Ground level or boom tip)

Eliminate the handling and maintenance concerns that accompany cabled remotes. Operate to a range of about 250 feet (76 m), varying with conditions.

- **Model NB4R** (R4 functions)

### One-Person Basket –

Strong but lightweight steel basket with 300-lb. (139-kg) capacity, gravity hung with swing lock and full body harness.

- **Model B1-S**
- **Model 2B1-S** (for dual locking baskets)

### Heavy-duty Personnel Basket –

1,200-lb. (544-kg) capacity steel basket with safety loops for four passengers. Gravity leveling 72- x 42-inch (183- x 107-cm) platform. Fast attachment and secure locking systems.

- **Model BSA-1**
- **Model BSA-R1** (provides rotation)

### Air-Conditioning for Crane Cab –

(Requires larger truck alternator) Provides excellent crane cab cooling to overcome the radiant heat from the sun reflection.

- **Model A/C**

### Auxiliary Winch 10,000-lb. Line Pull –

Second winch redundant to the main, planetary winch with boom tip “rooster sheave” to allow reeving of both winch lines.

- **Model 18AW**

### Work Lights –

- Amber flashing beacon mounted on crane cab
- Capacity indicator light outside of cab for visual display of load on hook versus capacity
- Spotlight mounted on cab, manually adjusted from the crane cab
- Worklight on boom, switch and wiring in cab to operate customer supplied worklight (without remote controls)
- Worklight in fixed position on crane cab with in cab power
- Worklight adjustable from crane with in-cab power

- **Model ABR**

- **Model CIE**
- **Model MSL**

- **Model WLB**
- **Model WLF**
- **Model WLR**

## Dimensions Specifications

SERIES	RETRACTED LENGTH	EXTENDED LENGTH	G	WEIGHT WITH OIL*
18103	31 ft (9.45 m)	103 ft (31.40 m)	69 in (1.75 m)	33,850 lb (15,354 kg)
18127	31 ft (9.45 m)	127 ft (38.72 m)	69 in (1.75 m)	35,275 lb (16,000 kg)
18142	34 ft (10.36 m)	142 ft (43.28 m)	87 in (2.21 m)	36,970 lb (16,769 kg)
1879	31 ft (9.45 m)	79 ft (24.08 m)	69 in (1.75 m)	31,815 lb (14,431 kg)

\*WEIGHT INCLUDES ALL ITEMS INCLUDING COMPLETE HO OUTRIGGERS, 2300 lb COUNTERWEIGHT, 375-lb BLOCK, DECKS AND SFO. BOOMS FULLY RETRACTED.

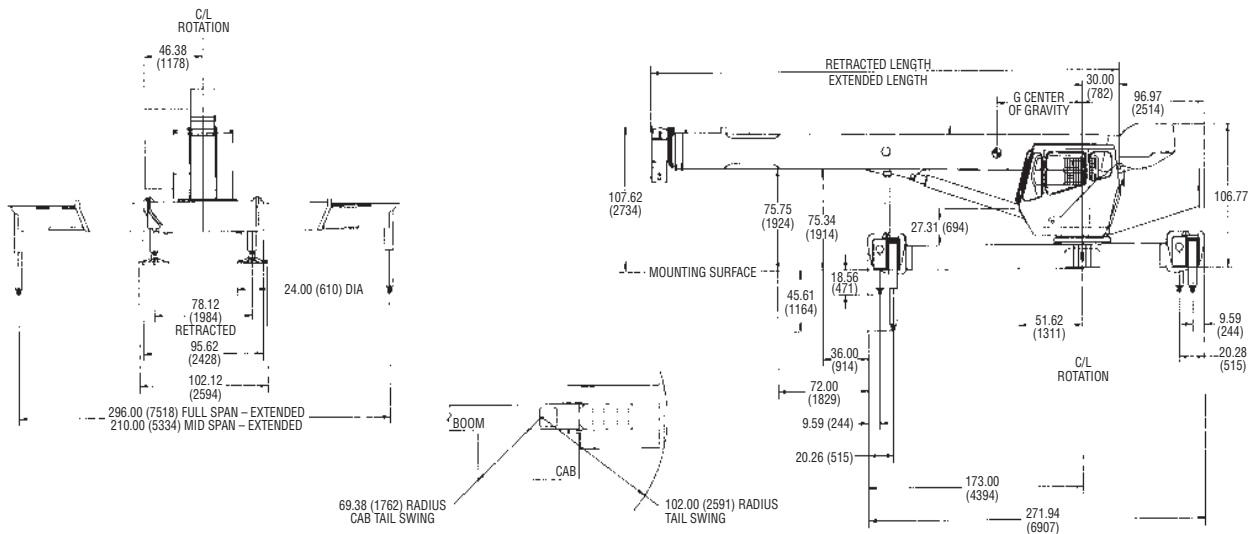

# 1800



**Manitowoc Crane Group - Americas**

Manitowoc, Wisconsin Facility  
Tel: [Int + 001] 920 684 6621  
Fax: [Int + 001] 920 683 6277  
Shady Grove, Pennsylvania Facility  
Tel: [Int + 001] 717 597 8121  
Fax: [Int + 001] 717 597 4062

**Manitowoc Crane Group - EMEA**

Europe Middle East & Africa  
Tel: [Int + 33] (0) 191 565 6281  
Fax: [Int + 33] (0) 4 72 18 20 20

**Manitowoc Crane Group - UK**

Europe Middle East & Africa  
Tel: [Int + 44] (0) 191 565 6281  
Fax: [Int + 44] (0) 191 564 0442

**Manitowoc Crane Group - Germany**

(Sales, Parts & Service)  
Tel: [Int + 49](0) 2173 8909 0  
Fax: [Int + 49] (0) 2173 8909-30

**Manitowoc Crane Group - France**

France & Africa (Sales, Parts & Service)  
Tel: [Int + 33] (0) 1 303 13150  
Fax: [Int + 33] (0) 1 303 86085

**Manitowoc Crane Group - Netherlands**

(Sales, Parts & Service)  
Tel: [Int + 31] (0) 76 578 39 99  
Fax: [Int + 31] (0) 76 578 39 78

**Manitowoc Crane Group - Italy**

Italy & Southern Europe (Sales, Parts & Service)  
Tel: [Int + 39] (0) 331 49 33 11  
Fax: [Int + 39] (0) 331 49 33 30

**Manitowoc Crane Group - Portugal**

Portugal & Spain (Sales, Parts & Service)  
Tel: [Int + 351] (0) 22 968 08 89  
Fax: [Int + 351] (0) 22 968 08 97

**Manitowoc Crane Group - Singapore**

Asia/Pacific excl China (Sales, Parts & Service)  
Tel: [Int + 65] 6861 1733  
Fax: [Int + 65] 6862 4040 / 4142

**Manitowoc Crane Group - Shanghai**

China (Sales, Parts & Service)  
Tel: [Int + 86] (0) 21 64955555  
Fax: [Int + 86] (0) 2164852038

**Manitowoc Crane Group - Beijing**

China (Sales, Parts & Service)  
Tel: [Int + 86] (0) 10 646 71690  
Fax: [Int + 86] (0) 10 646 71691

**Manitowoc Crane Group - Middle East**

Sales  
Tel: [Int + 971] (0) 4 348 4478  
Fax: [Int + 971] (0) 4 348 4478  
(Parts & Service)  
Tel: [Int + 973] (0) 9 660 899  
Fax: [Int + 973] (0) 2 707 740

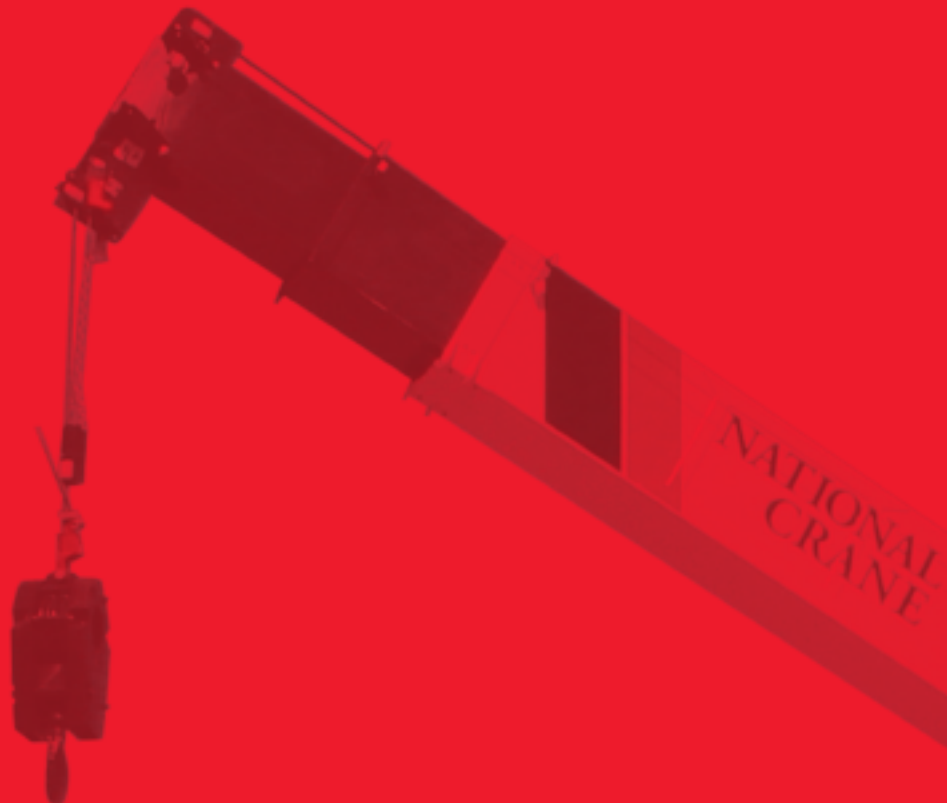

**Distributed By:**



[www.manitowoccrane.com](http://www.manitowoccrane.com)

Constant improvement and engineering progress make it necessary that we reserve the right to make specification, equipment, and price changes without notice. \*Illustrations/photos shown may include optional equipment and accessories, and may not include all standard equipment.